

# PHILIPS

100 Craftway Dr.  
Littlestown, Pennsylvania 17340-0128  
Phone: (717) 359-7131

## INSTALLATION INSTRUCTIONS: SP-200/201/203/204/206/207

### Safety, Warnings and Suggestions

- <sup>1</sup> *Avoid* installing fixtures in locations where water collects and stands for prolonged periods.
- <sup>2</sup> *Make* sure that electrical power is disconnected before any work is performed.
- <sup>3</sup> *All* wiring and installation should meet local, state and national electrical codes.

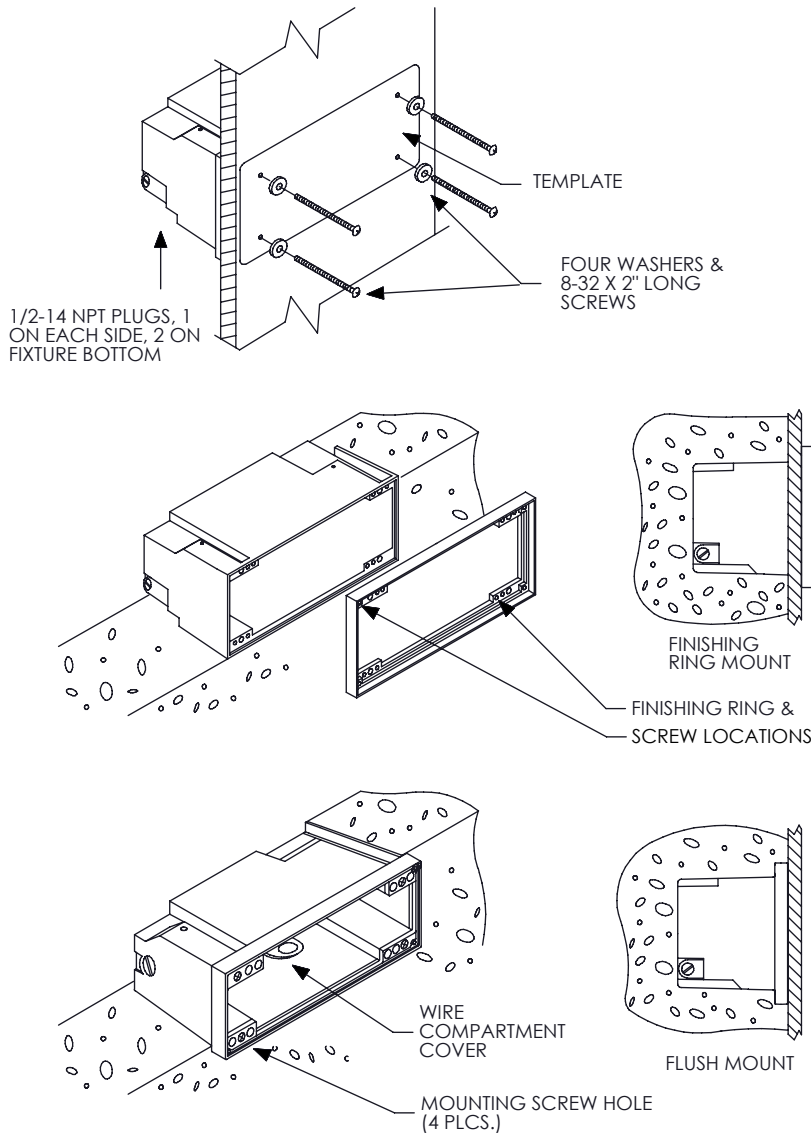
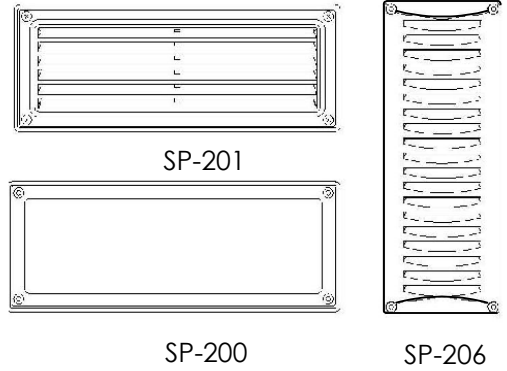

1. Level supplied template on wood support frame and drill designated 3/16" diameter clearance holes.
2. Remove the 1/2" NPT plugs from the sides/bottom of the housing and pull the supply wire through into the housing.
3. Install the plastic protective shield (if supplied) into the housing and be sure all unused electrical plugs are replaced. Finishing ring may be removed now and replaced on housing after concrete pour.
4. Secure housing to wood support with screws supplied in hardware packet.
5. Pour concrete.
6. If finishing ring was removed, replace it and tighten flat head screws. If screws are not tight, fixture may leak.



# PHILIPS

100 Craftway Dr.  
Littlestown, Pennsylvania 17340-0128  
Phone: (717) 359-7131

## INSTALLATION INSTRUCTIONS: SP-200/201/203/204/206/207 MASONRY (MM)

### Safety, Warnings and Suggestions

- Avoid** installing fixtures in locations where water collects and stands for prolonged periods.
- Make** sure that electrical power is disconnected before any work is performed.
- All** wiring and installation should meet local, state and national electrical codes.

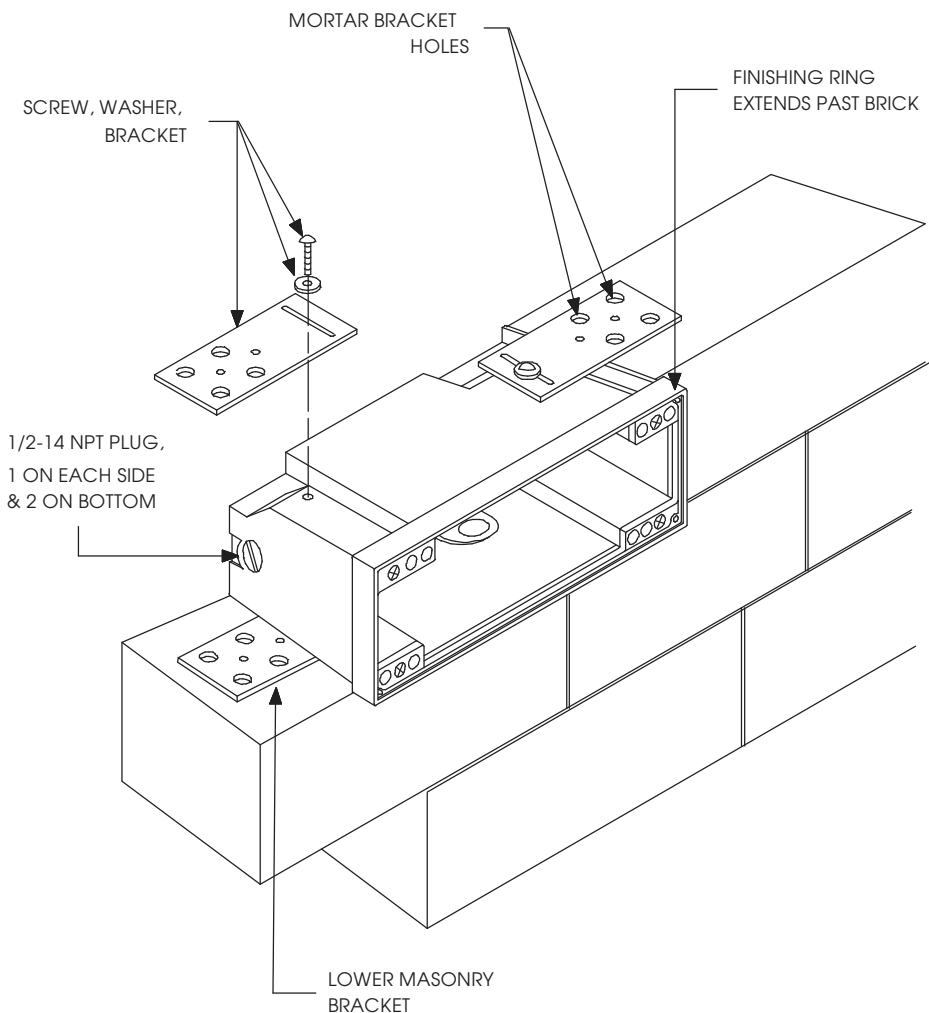

1. Install two screws through washers and lower masonry brackets into tapped housing holes on bottom of fixture.

2. Remove the 1/2" NPT plugs from the side/bottom of the housing and pull the supply wire through and into the housing.

3. Press fixture and lower masonry brackets into layer of mortar so that the mortar penetrates through the holes of the masonry bracket.

4. After laying another course of blocks, install the two upper masonry brackets onto the housing as in step 1.



# PHILIPS

100 Craftway Dr.  
Littlestown, Pennsylvania 17340-0128  
Phone: (717) 359-7131

## INSTALLATION INSTRUCTIONS: SP-200/201/203/204/206/207 EXISTING STUD WALL (ES)

### Safety, Warnings and Suggestions

- <sup>1</sup> **Avoid** installing fixtures in locations where water collects and stands for prolonged periods.
- <sup>2</sup> **Make** sure that electrical power is disconnected before any work is performed.
- <sup>3</sup> **All** wiring and installation should meet local, state and national electrical codes.



SP-200



SP-201



SP-203



SP-204



SP-206



SP-207

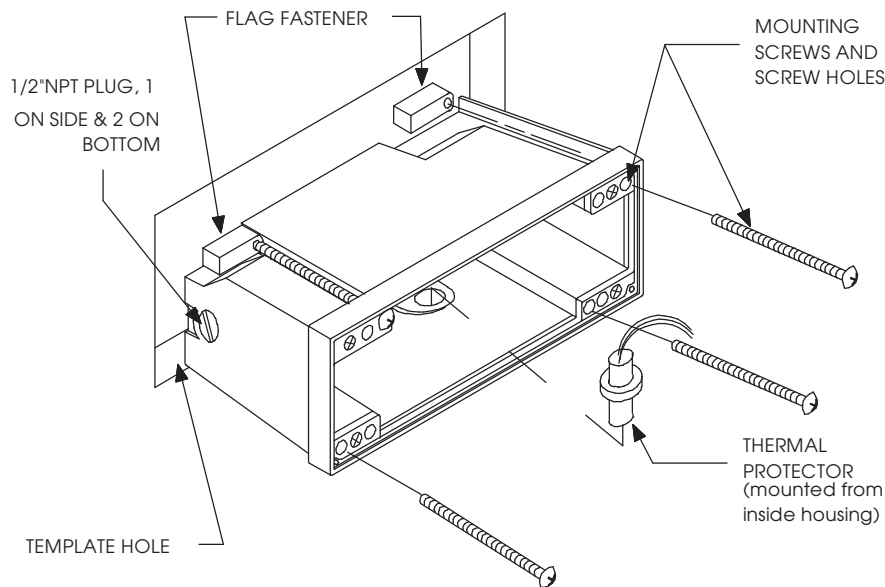

1. Using the template supplied, cut a level hole through the existing wall between existing studs. Failure to level hole will cause the fixture to have a tilted appearance.

2. Push the four mounting screws through the housing holes and into rear channels. (note: thin membrane covers the housing holes and may require forcing the screws through to penetrate the membrane).

3. Place flags flat on rear of housing and thread screws into flags until the screws are completely through the flags.

4. Remove the 1/2" NPT plugs from the side/bottom of the housing and pull the supply wire through into the housing.

5. Push housing into the hole in the wall and tighten the four mounting screws until the flag fasteners have drawn tightly against the rear surface of the wall.

6. Install thermal protector (attached to electrical chassis.)

